

VaporPlus™ Humidification System

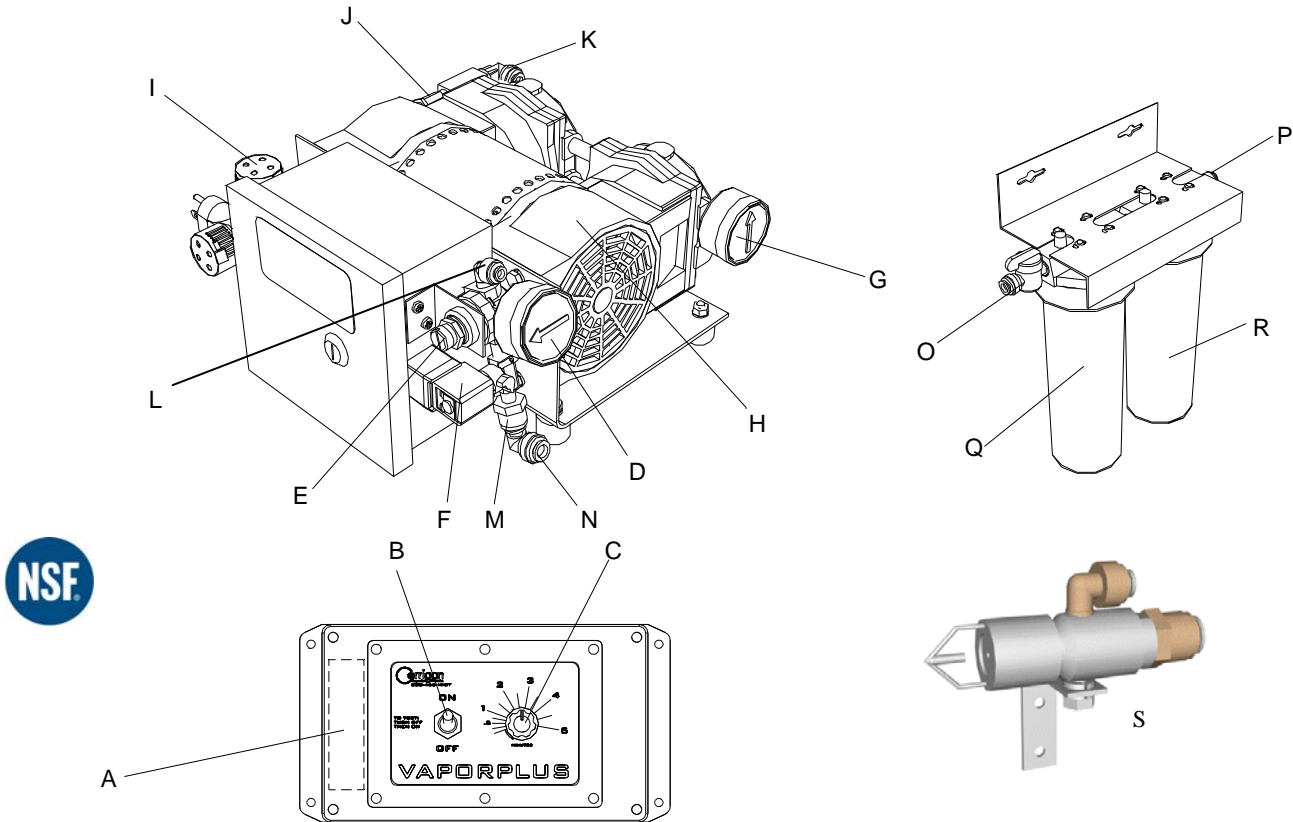

Description	Part #
A Timing module	T202V
B On/off toggle switch	E205
C Time adjustment assembly	T202W
D Water pressure gauge	WPGCBM30
E Water pressure regulator	WPR362
F Water solenoid valve	SVNC18120L
G Air pressure gauge	WPGCBM60
H Air compressor	AC
I Air Filter Element	ACAF3
Power Relay (not shown)	ER203
Transformer (not shown)	ET15343
Capacitor (not shown)	ACCAP
J Air relief valve	ACPRV
K 3/8 x 1/4 Male Elbow Adapter	JGME3814
L 1/4 Male Elbow Adapter	JGME14
M 3/8 x 1/8 Male Adapter	JGMC3818
N 3/8 Stem Elbow	JGSEC38
O 3/8 Ball Valve	JGBV38
P 3/8 Male Adapter	JGMC38
Q 10" KDF media cartridge	FCKDF10
R 10" sediment cartridge	FCRB110
S1 Nozzle (for models VP & VPSL)	VPNZL1
S2 Nozzle (for models VP2 & VPSL2)	VPNZL2
VaporPlus timer control	VPSCT
Compressor/Control assembly	VPCU
Dual filter with cartridges	600DF